

Simple Harmonic Motion–Pendulum

Mechanics: simple harmonic motion, pendulum

GLX setup file: **pendulum**

Qty	Equipment and Materials	Part Number
1	PASPORT Xplorer GLX	PS-2002
1	PASPORT Motion Sensor	PS-2103
1	Universal Table Clamp	ME-9376B
1	Rod, 45 cm	ME-8736
1	Pendulum Clamp	SE-9443
1	Meter Stick	SE-8695
1	Balance	SE-8723
1	Basic Calorimetry Set (metal masses)	TD-8557
2 m	Braided Physics String	SE-8050

Purpose

The purpose of this activity is to determine how the mass and length of a pendulum affect the oscillation period of the pendulum.

Background

A simple pendulum consists of a particle of mass m , attached to a frictionless pivot by a cable of length L and negligible mass. When the particle is pulled away from its equilibrium position by an angle and released, it swings back and forth. The length L and the acceleration due to gravity g (9.8 m/s^2) determine the period of a simple pendulum for small angles.

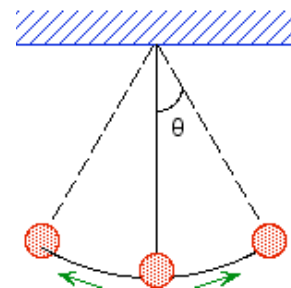

$$T = 2\pi\sqrt{\frac{L}{g}}$$

Safety Precautions

- Follow all directions for using the equipment.

Preview

Use a Motion Sensor to measure the period of a pendulum. Determine the relationship of the period of oscillation of a pendulum to the length of the pendulum and the mass of the pendulum.

Prediction

1. How will changes in the mass of a pendulum change the period of oscillation of the pendulum?
2. How will changes in the length of a pendulum change the period of oscillation of the pendulum?

Procedure

GLX Setup

1. Turn on the GLX (Ⓢ) and open the GLX setup file labeled **pendulum**. (Check the Appendix at the end of this activity.)
- The file is set up so that motion is measured 20 times per second (20 Hz). The Graph screen opens with a graph of Position (m) versus Time (s).
3. Connect the Motion Sensor to a sensor port on the top of the GLX. Set the range selection switch on the sensor to 'far' (person).

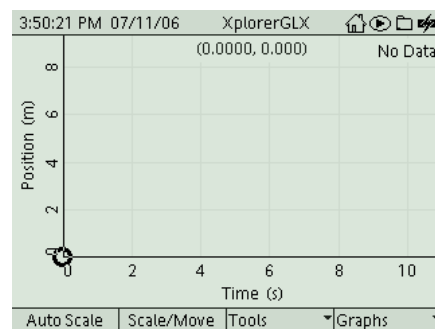

Fig. 1: Graph screen

Equipment Setup

1. Mount a rod so it is vertical. Attach the pendulum clamp to the rod near the top.
2. Measure and record the mass m of the first pendulum bob. Put the first pendulum bob at the middle of a 2 m long piece of string.
3. Attach the string to the pendulum clamp. Put the ends of the string on the inner and outer clips of the clamp so the string forms a 'V' shape as it hangs.
4. Measure and record the length L of the pendulum from the bottom edge of the pendulum clamp to the middle of the first pendulum bob.
5. Place the Motion Sensor next to the pendulum bob. Align the sensor so the brass colored disk is vertical and facing the bob and is aimed along the direction that the pendulum will swing.
6. Adjust the pendulum clamp up or down so that the pendulum bob is directly centered in front of the brass colored disk on the front of the sensor.
7. Move the sensor away from the hanging pendulum bob about 25 cm (10 in).
- NOTE: The procedure is easier if one person handles the pendulum and a second person handles the Xplorer GLX.

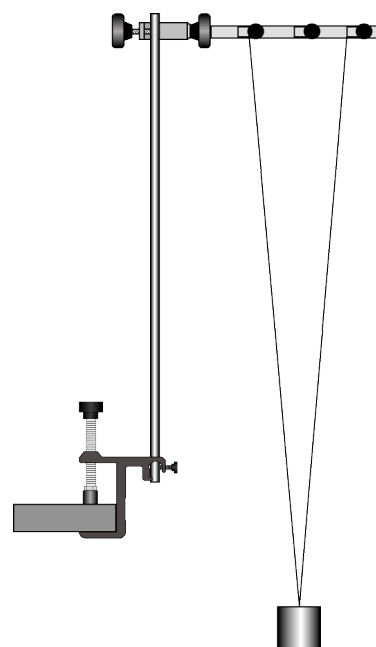

Fig. 2 Equipment setup

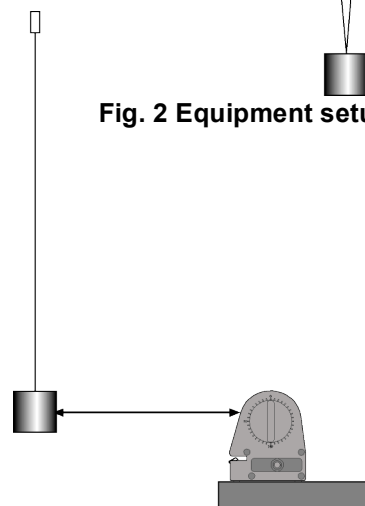

Fig. 3: Sensor and pendulum

Record Data: Changing Mass

1. Pull the pendulum bob back about 10 cm and let it go. Allow the pendulum to swing back and forth about five times to smooth its motion.
2. Press Start (▶) to start recording data.
3. After ten seconds, press (▶) to stop recording.
4. For a second run, remove the first pendulum bob. Measure and record the mass of a second pendulum bob and put it on the string. Re-measure the pendulum length and adjust the string so the length is the same as for the first pendulum bob.
5. Repeat the data recording procedure.
6. Measure and record the mass of a third pendulum bob and put it on the string in place of the second pendulum bob. Repeat the data recording process.

Record Data: Changing Length

7. Put the first pendulum bob back on the string. Adjust the pendulum clamp and the string so the length of the pendulum is 15 cm shorter than the original length. Record the new, shorter pendulum length.
8. Perform the same data recording procedure.
9. For another run, shorten the length another 15 cm. Record the new pendulum length and repeat the data recording procedure.

Analysis

Use the Graph screen to examine the position versus time for each data run. Determine the period of the pendulum's swing in each run.

1. To change the Graph screen to show a specific run of data, press (✓) to activate the vertical axis menu. Press the arrow keys (↖) to move to 'Run #_' in the upper left hand corner or upper right corner. Press (✓) to open the menu, select the data run in the menu, and press (✓) to activate your choice.
2. To find the period of the swinging pendulum, use the 'Delta Tool'. Use the arrow keys to move the cursor to the peak in the graph.
Press F3 (F3) to open the Tools menu. Select 'Delta Tool' and press (✓) to activate your choice.
3. Use the arrow keys to move the cursor to the next peak in the graph.
4. The 'Delta Tool' values for Δy and Δx are along the y-axis and x-axis respectively. Record the Δx value as 'Period 1'.

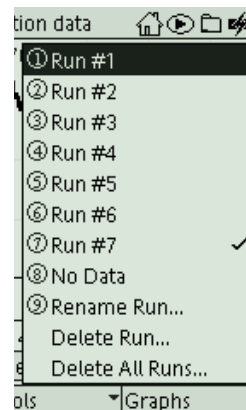

Fig. 4: Select 'Run'

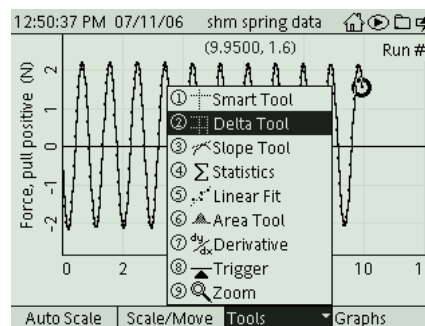

Fig. 5: Select 'Delta Tool'

5. Repeat the analysis process to find the period of time for five separate swings. Calculate the average period and record it in the Data Table.
6. Repeat the analysis process for the other runs of data.

Record your results and answer the questions in the Lab Report section.

Appendix: Opening a GLX File

To open a specific GLX file, go to the Home Screen (⌂). In the Home Screen, select Data Files and press (✓) to activate your choice. In the Data Files screen, use the arrow keys to navigate to the file you want. Press (F1) to open the file. Press the Home button to return to the Home Screen. Press (F1) to open the Graph.

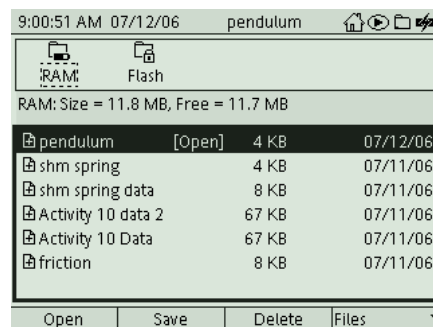

Lab Report – Activity 13: Simple Harmonic Motion–Pendulum**Name** _____ **Date** _____**Prediction**

1. How will changes in the mass of a pendulum change the period of oscillation of the pendulum?

2. How will changes in the length of a pendulum change the period of oscillation of the pendulum?

Data

Sketch a graph for one run of position versus time. Include units and labels for your axes.

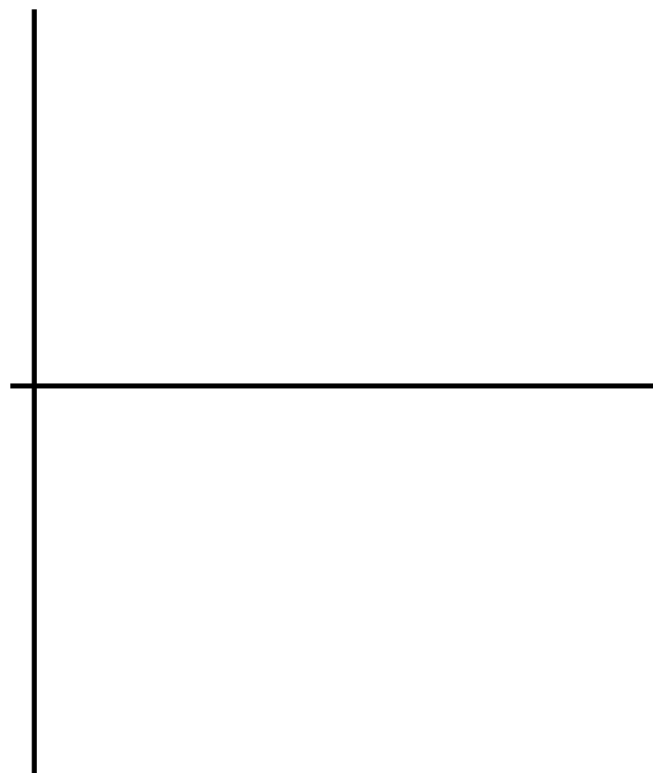

Data Table 1

Original length, L = _____

Item	Mass (kg)	Period 1	Period 2	Period 3	Period 4	Period 5	Average
Pendulum 1							
Pendulum 2							
Pendulum 3							

Item	Length (m)	Period 1	Period 2	Period 3	Period 4	Period 5	Average
Length 1							
Length 2							
Length 3							

Questions

1. What is the shape of the graph of position versus time for the pendulum?
2. What happened to your measured values for the period when you changed the mass of the pendulum bob?
3. What happened to your measured values for the period when you changed the length of the pendulum?

Calculation

Calculate a theoretical value for the period of the pendulum for the original length of your pendulum. Calculate the percent difference between the theoretical value for period and the average measured value for period that you recorded in the data table.

$$T = 2\pi\sqrt{\frac{L}{g}}$$

$$\%diff = \left| \frac{\text{theoretical} - \text{measured}}{\text{theoretical}} \right| \times 100\%$$

Item	Value
Theoretical period	
Average period	
Percent difference	